

Second Generation Of PID Controllers For Reference In Put Tracking

Sajay paliwal¹

ABSTRACT

The paper presents the birth of the second generation of PID controllers for possible replacement of the first generation of PID controllers. It presents the dynamics of the control system incorporating one of the controllers: PID, I-PD, PD-PI and PI-PD and a highly oscillating second order-like process. The controllers are tuned and compared with a conventional tuned PID controller. The performance is judged through the maximum percentage overshoot, maximum percentage undershoot and these settling time characteristics of the time response of the control system to a unit step reference input.

Keywords: Conventional PID controller, second generation of PID controllers, I-PD controller, PD-PI controller, PI-PD controller, 2DOF controller.

I. INTRODUCTION

The first generation of PID controllers were introduced in 1939 by Taylor Instruments Company and the Foxboro Instrument Company [1]. Since that time they found wide applications in industry and researchers efforts were paid to tune their parameters. However, the first generation of PID controllers suffered from a kick phenomena in the control system using PID controller appeared in the step time response associated with its reference input[2].

Professor Galal Hassaan run an intensive research from 2014 onward to investigate the application of a large number of controllers belonging to what is he called 'the second generation of PID controllers' to control processes having difficult dynamics such as unstable processes and highly oscillating ones. Some of the outcome of his research for reference in put tracking is:

- I-PD controller in 2014 [3].
- PD-PI controller in 2014 [4].
- PI-PD controller in 2014 [5].
- PPI controller in 2015 [6].
- PI-P controller in 2015 [7].
- 2DOF controller in 2015 [8].
- PD-I controller in 2018 [9].

II. HIGHLY OSCILLATING SECOND-ORDER-LIKE PROCESS

The applicability of the proposed controllers was tested using a second-order-like process having the characteristics:

Natural frequency, ω_n :	10	rad/s
Damping ratio, ζ :	0.05	
Maximum percentage overshoot, $O_{s_{max}}$:	85.4	%
Settling time, T_s :	6	s

¹*Department of Mechanical Engineering RDEC, Ghaziabad, Email- sanjaypaliwal@gmail.com

III. PROCESS CONTROL USING A CONVENTIONAL PID CONTROLLER

If this process is controlled using a conventional PID controller in a unit feedback block diagram, the control system has a closed loop transfer function given by [10]:

$$M(s) = (b_0s^2 + b_1s + b_2) / (a_0s^3 + a_1s^2 + a_2s + a_3) \tag{1}$$

Where: $b_0 = \omega_n^2 K_d K_i$, $b_1 = \omega_n^2 K_{pc} b = \omega_n^2 K_a a_0 = 1$, $a_1 = \omega_n^2 K_{pc}$, $a_2 = \omega_n^2 (1 + K_{pc})$, $a_3 = 2\zeta\omega_n$, $a_0 = \omega_n^2 K_i$

K_{pc} = proportional controller gain. K_i = integral controller gain.
 K_d = derivative controller gain.

Tuning of the Conventional PID Controller:

The PID controller was tuned by the author using the MATLAB optimization tool box, ITAE objective function and functional constraints on the maximum percentage overshoot, settling time and stability. This tuning procedure resulted in the following PID controller parameters:

$$K_{pc} = 1.3456, K_i = 9.9714, K_d = 0.1416 \tag{2}$$

Now, plotting the unit step response of the control system using the transfer function in Eq.1 and the tuned controller parameters in Eq.2 using the „step“ command of MATLAB reveals the step time response to reference input given in Fig.1. Here, are some important comments:

- The kick associated with the use of the PID controller is clear at 0.125 s.
- There is a maximum percentage overshoot of 0.968%.
- There is a settling time of 0.55 s.
- We will examine now how the controllers of the second generation of PID can solve the kick phenomenon problem.

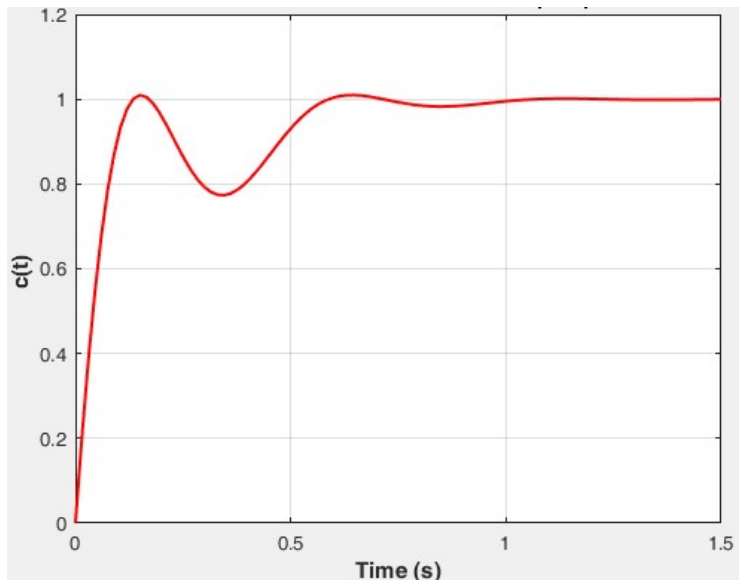

Figure1: Unit Step Time Response using a Tuned PID Controller.

IV. CONTROLLING THE PROCESS USING AN I-PD CONTROLLER

The block diagram of the control system incorporating an I-PD controller and the controlled process is shown in Fig.2 [3,11]. Using the block diagram of Fig.2, the transfer function of the control system, $M(s)$ is [3]:

$$M(s) = b_0 / (a_0s^3 + a_1s^2 + a_2s + a_3) \tag{3}$$

Where: $b_0 = \omega_n^2 K_i$, $a_0 = 1$, $a_2 = \omega_n^2 (1 + K_{pc})$, $a_1 = \omega_n^2 K_d + 2\zeta\omega_n$, $a_3 = \omega_n^2 K_i$

Tuning of the I-PD Controller:

The I-PD controller was tuned using the MATLAB optimization tool box, ISE objective function without any functional constraints. This tuning procedure resulted in the following I-PD tuned controller parameters[3]:

$$K_{pc}=1.7523, K_i=5.3314, K_d= 0.1113 \quad (4)$$

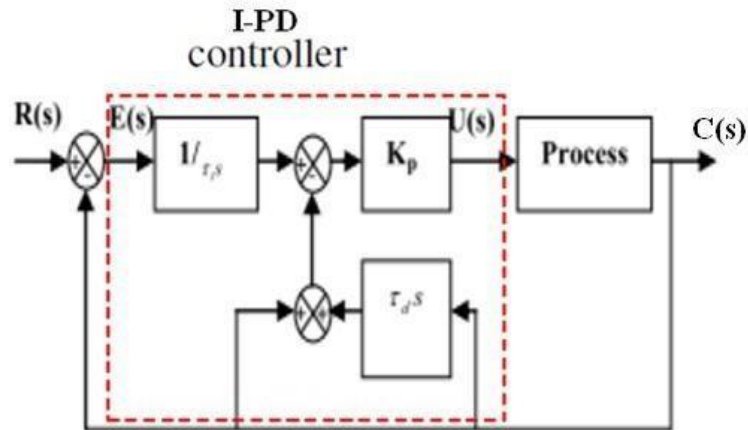

Figure2:I-PDControlledProcess[3,11].

Now, plotting the unit step response of the control system using the transfer function in Eq.3 and the tuned controller parameters in Eq.4 using the „step“ command of MATLAB reveals the step time response to reference input given in Fig.3 compared with that using the conventional PID controller. Here, are some important comments:

- The kick was completely eliminated.
- There is a zero maximum percentage overshoot compared with 0.968% for the conventional PID controller.
- These tting time is 1.9s compared with 0.55 s for the conventional PID controller.

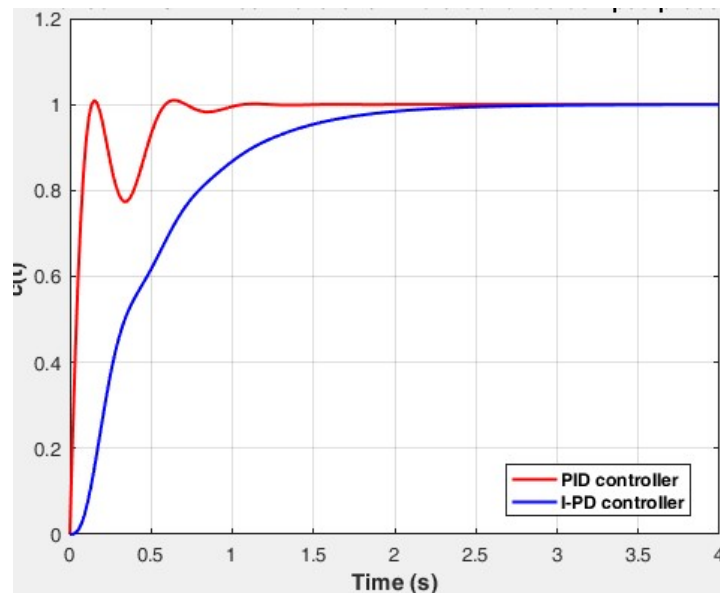

Figure3:Unit Step Time Response using a Tuned I-PD Controller.

V. CONTROLLING THE PROCESS USING A PD-PI CONTROLLER

The block diagram of the control system in incorporating a PD-PI controller and the controlled process is shown in Fig.4 [4,12].

PD-PI Controller Transfer Function, $G_c(s)$:

Using the block diagram in Fig.4, the transfer function of the PD-PI controller, $G_c(s)$ is given by:

$$G_c(s) = (1/s)[K_{pc}K_d s^2 + (K_{pc} + K_d K_i)s + K_i] \quad (5)$$

Using the block diagram of Fig.4, the second order process transfer function and the controller transfer function in Eq.5, the transfer function of the control system, $M(s)$ is [4]:

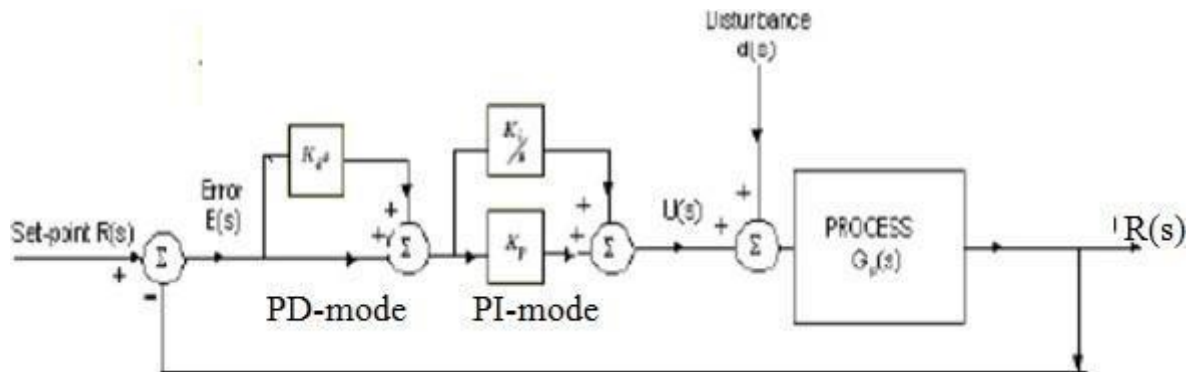

Figure4: PD-PI Controlled Process [12].

$$M(s) = (b_0 s^2 + b_1 s + b_2) / (a_0 s^3 + a_1 s^2 + a_2 s + a_3) \quad (6)$$

Where: $b_0 = K_{pc} K_d \omega_n^2$, $b_1 = (K_{pc} + K_d K_i) \omega_n^2$

$b_2 = K_i \omega_n^2$

$a_0 = 1$, $a_1 = 2\zeta\omega_n + K_{pc} K_d \omega_n^2$, $a_2 = \omega_n^2(1 + K_{pc} T_d)$, $a_3 = K_i \omega_n^2$

Tuning of the PD-PI Controller:

The PD-PI controller was tuned using the MATLAB optimization toolbox, ISE objective function without any functional constraints. This tuning procedure resulted in the following tuned controller parameters [4]:

$$K_{pc} = 33.2092, K_d = 43.1119, K_i = 34.1119 \quad (7)$$

Now, plotting the unit step response of the control system using the transfer function in Eq.6 and the tuned controller parameters in Eq.7 using the „step“ command of MATLAB reveals the step time response to reference input given in Fig.5 compared with that using the conventional PID controller. Here, are some important comments:

- The kick was completely eliminated.
- There is a zero maximum percentage overshoot compared with 0.968% for the conventional PID controller.
- These settling time is zero compared with 0.55s for the conventional PID controller.
- The step time response to a unit step reference input has a step shape which is completely ideal from system dynamics point of view.

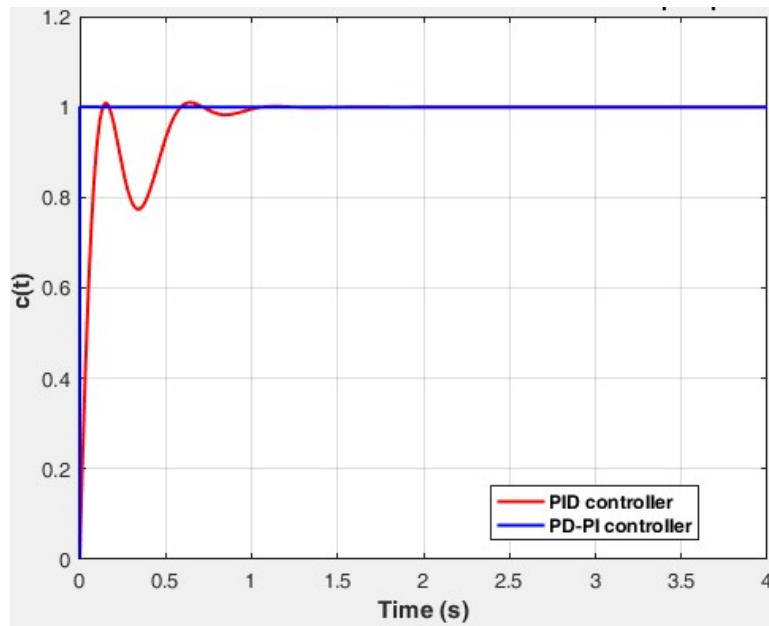

Figure5: Unit Step Time Response using a Tuned PD-PI Controller.

VI. CONTROLLING THE PROCESS USING AN PI-PD CONTROLLER

The block diagram of the control system in incorporating a PI-PD controller and the controlled process is shown in Fig.6 [5,13].

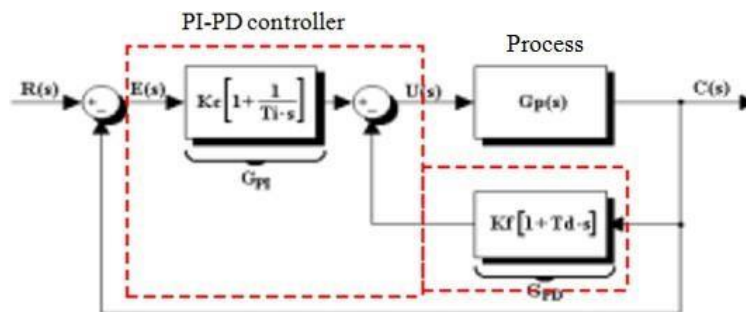

Figure6:PI-PD Controlled Process[5,13].

Mathematical model of the PD-PI Controller:

Using the block diagram in Fig.6, the mathematical model of the PI-PD controller is:

$$U(s)=[K_c+(K_i/s)[R(s)-C(s)]-(K_f+ K_d s)C(s) \tag{8}$$

Using the block diagram of Fig.6, the second order process transfer function and the controller mathematical model in Eq.8 ,the transfer function of the control system, M(s) is[5]:

$$M(s)=(b_0 s+ b_1)/(a_0 s^3 +a_1 s^2+ a_2 s+a_3) \tag{9}$$

Where: $b_0=K_c \omega_n^2$, $b_1= K_i \omega_n^2$, $a_0= 1$, $a_1= 2\zeta \omega_n+ K_d \omega_n^2$, $a_2=(1+K_c+ K_f)\omega_n^2$, $a_3=K_i \omega_n$

Tuning of the PI-PD Controller:

The PI-PD controller was tuned using the MATLAB optimization tool box, ISE objective function without any functional constraints. This tuning procedure resulted in the following tuned controller parameters [4]: $K_c= 10$, $K_f= 1$, $K_i= 15$, $K_d=0.9994$ (10)

Now, plotting the unit step response of the control system using the transfer function in Eq.9 and the tuned controller parameters in Eq.10 using the „step“ command of MATLAB reveals the step time response to reference input given in Fig.7 compared with that using the conventional PID controller. Here, are some important comments:

- The kick was completely eliminated.
- There is a zero maximum percentage overshoot compared with 0.968% for the conventional PID controller.
- The settling time is 0.82 s compared with 0.55s for the conventional PID controller.

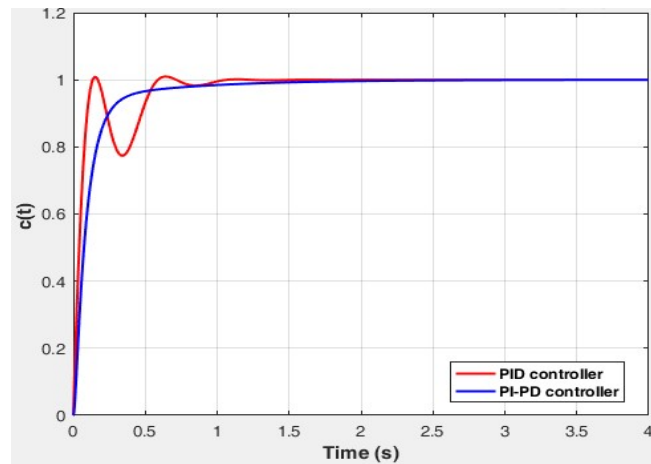

Figure7:Unit Step Time Response using a Tuned PI-PD Controller.

VII.CONCLUSION

- The paper investigated the use of a PID controller from the first generation and three controllers from the second generation of PID controllers to control a highly oscillating second order-like process.
- The three used controllers from the second generation of PID controllers are the I-PD, PD-PI and PI-PD controllers.
- The main objective of the new controllers was to get rid of the kick associated with the step reference input time response when using PID controllers.
- The three controllers eliminated completely the kick phenomena.
- The performance of the control system was improved specially regarding the maximum percentage overshoot and the maximum percentage undershoot.
- The maximum percentage overshoot was reduced to zero compared with 0.968% for the PID controller.
- The maximum percentage undershoot was reduced to zero compared with 22.73% for the PID controller.
- The PID controller resulted in a faster step response except when compared with the PD-PI controller. The settling time was 0.55 s compared with 1.9s for the I-PD controller, zero for the PD-PI controller and 0.82 s for the PI-PD controller.

VIII. REFERENCES

- S.Bennett, "Development of the PID controller", IEEE Control Systems, vol.13, issue6, 1994, pp.58-62.
- A.Faraj, A.A Ibaguland M. Muhammed, "Enhancement of control signal using a modified parallel PID controller", Universal Journal of Control and Automation, vol.6, issue 1, 2018, pp.1-12.
- G. Hassaan, "Tuning of an I-PD controller used with a highly oscillating second order process", International Journal of Mechanical Engineering and Technology, vol.5, issue 5, 2014, pp.115-121.
- A.G. Hassaan, "Tuning of a PD-PI controller used with a highly oscillating second order process", International Journal of Scientific and Technology Research, vol.3, issue7, 2014, pp.145-147.
- A.G. Hassaan, "Tuning of an PIPD controller used with a highly oscillating second order process", International Journal of Research and Innovative Technology, vol.1, issue5, 2014, pp.67-69.

- A.G. Hassaan, "PPI controller tuning for use with a highly oscillating second order process", *International Journal of Science and Engineering*, vol.1, issue 3, 2015,pp.32-37.
- A.G. Hassaan,"Tuning of an PI-P controller used with a highly oscillating second order process", *International Journal of Research in Information Technology*, v ol.3, issue7, 2015,pp.206-231.
- A.G. Hassaan, "Tuning of an 2 DOF controller used with a highly oscillating second order process", *International Journal of Modern Trends in Engineering and Research*, vol.2,issue 8, 2015,pp.292-298.
- G. Hassaan, "Novel PD-I controller for underdamped second order process-like processes", *International Journal of Engineering and Techniques*", vol.4, issue 2,2018,pp.181-187.
- A.G.Hassaan,"On simple tuning of PID controllers for under damped second order processes", *International Journal of Mechanical and Production Research and Development*,vol.4, issue 3, 2014, pp.61-68.
- S.Prasad, S.Varghese and P.Balakrishnan."Optimization ofI-PD controller for a FOLIPD model using particles warm intelligence", *International JournalofComputerApplications*,vol.43, issue9, 2012, pp.23-26.
- T. Jainand M. Nigram, "Optimization of PD-PI controller usings warm intelligence", *International Journal Theoretical and Applied Information Technology*, vol.6, 2008,pp.55-59.
- J. Rodriguez and A. Coelho, "IMC tuning of a PI-PD controller FOPDT, SOPDT and IFOPDT plants", *Second Mercosur Congresson Chemical Engineering*, 2005.