

Diabetes Detection Using Convolutional NeuralNetworks (Cnn) Based Model

Bhavesh Digey, Sharvari Vaidya, Pranjali Sudrik, Nikhil Vaidya

Department of Instrumentation Engineering, D Y Patil, Deemed to be university, Ramrao Adik Institute of Technology, Nerul, Navi Mumbai 400706, India

Abstract: Diabetes, also known as Diabetes Mellitus is a disease that happens to a person when one's blood glucose or blood sugar is extremely high. Insulin is a hormone secreted by the organ pancreas and helps to convert the blood glucose into useful energy for the body. In some cases, the body doesn't produce enough, or any amount of insulin or doesn't use the produced insulin properly. Hence the Glucose remains in the blood and doesn't reach the body cells. Thus, having a lot of glucose in your blood can causes health problems, which is what exactly happens in Diabetes. Long-term complications of Diabetes develop gradually. Having Diabetes for a long time along with uncontrolled blood sugar levels can cause dangerous complications. In the due course, diabetes complications may be disabling or even life- threatening. Making things even worse, there is no cure for this disease yet! Even though there's no cure for diabetes, it can be treated and controlled, and some people may go into a state of remission. But the very first step towards controlling and minimizing the ill effects of Diabetes is – the early detection of the disease! Thus, we need comfortable, reliable, and quick methods of detection. Hence, we are proposing an efficient, reliable, comfortable, and time-saving Diabetes detection system for Diabetes detection using diabetic Retinopathy and Implementation of Convolutional Neural Networks (CNN). The level of Diabetic retinopathy present will also give a direct indication about the level of Diabetes. The implementation of this method of Diabetes detection will increase accuracy, efficiency, and ease of Diabetes detection, and further the prognosis and treatment. Also, it will prove to be a better alternative to conventionaltesting for the disease.

Keywords—Diabetes, Diabetic Retinopathy, Convolutional Neural Networks (CNN), Retinal Images, Convolution,

Accuracy

1 INTRODUCTION

In this era where sugar is killing more people than gunpowder, it is imperative to find a solution to control this outburst epidemic. Hence, we aim to create a simple,patient friendly, accurate as well as a very quick method of Diabetes detection the knowledge of Diabetic retinopathy. The use of this technique along with the implementation of a Convolutional Neural Networks (CNN) model will prove to be a better alternative to the conventional Diabetes detection test. Here, we will be using images of the retina of the patient, to understand his/her physiological conditions, potential health risks, challenges, and condition of the pancreas. Similarly, we are using Diabetic Retinopathy as an extremely useful technique for diabetes detection as it indicates weakness in the concerned organs

long before the symptoms appear. Diabetes is also known as "The Silent Killer". Diabetic patients are prone to several health problems like Cardiovascular problems, Eye damage, Skin problems, Kidney damage, and even Depression! Today's hectic life and carefree eating and diet habits have led to a rise in the number of people having diabetes. This disease is not just life threatening, but it can also deteriorate the quality of your life, leading to many other health issues. And, the worst part is that Diabetes has no cure! Hence, the only way of treating and controlling this disease is early detection. Hence, to create a system that detects the disease much before the symptoms start to appear is the main motive behind this project. Along with this, we also aim to increase patient comfort and decrease the time required for detection through the implementation of this project. To use the knowledge of Biomedical engineering and deep learning and create an efficient Diabetes detection system, is the main motivation behind the creation and implementation of this project. We have created and implemented a Diabetes detection system. We have acquired a dataset consisting of Retina images of the subjects and we will be processing those images as per requirement. Using Convolutional Neural Networks (CNN) model technique obtains accurate results. In this manner, we find out whether the subject has Diabetes or not. Our proposed automated system detects the presence of Diabetes in the individual based on the study of Diabetic Retinopathy. The System also predicts the level of Diabetes in each subject on a scale of 0 (zero) to 4 (four).

2 LITERATURE SURVEY

We have referred to this research paper titled Diagnosis of Diabetes using Computer methods: Soft computing methods for diabetes detection using Iris [1] which is authored by Piyush Samant, Ravinder Agarwal. This research paper approaches Diabetes detection using Iridology and Computer Aided Manufacturing (CAM). This old technique is quite famous for analysing structures or patterns, tissue weakness indications, colour, shape, elevation, structure, etc. for disease diagnosis. The complete procedure was extremely simple and was carried out without the intervention of any Iridologist. We also received many new insights and detailed information about various methods feature extraction. A total of 63 (sixty-three) features were extracted in this process and each extraction gave some valuable information about the tissue condition. The Overall accuracy obtained through this process was 89.66%. This proposed technique also has various advantages over the conventional Diabetes detection method. This system is cost effective and non-invasive; hence it is very convenient for the patient. Though the author suggests that it is extremely essential to study and compare various predictive modelling methods, to arrive at the most effective one. We have also referred to this research paper titled Diabetes prediction system based on Iridology using Machine learning [2] authored by Ratna Aminah, Adhi Harmoko Saputaro. It is one of the standard papers for reference. This paper focuses on and stresses the use of Iridology as it helps in the detection of the disease much before the symptoms start to occur. Here, a diabetes prediction system has been constructed using the Machine Learning (ML) Technique. Usage of a particular device for data collection (image acquiring) leads to a very sophisticated data set. This paper uses the GLCM (Gray Level Co-Occurrence Matrix) method for feature extraction and the kNN (k Nearest Neighbour) method is used for image classification and further the prediction. An accuracy of 85.6% was obtained through the implementation of this system. An extensive literature survey and a thorough understanding of both research papers helped us to create a proper methodology for our proposed system. We gained valuable insights about Iridology and Iris detection system. Also, various

techniques like Complementary and Alternative medicine (CAM) and Machine learning were used. Along with these we also studied other techniques that could be used for building a model for a Diabetes detection system based on the principle of Iridology and Iris Recognition. This research helped us in finalizing the model which we are aiming to implement in our proposed system.

3 PROPOSED METHODOLOGY

Initially we will understand the Block diagram / Flowchart of the proposed system. Every step has its own significance which is explained below. In the section of proposed work we will understand and gain valuable insights on the working principle and driving concepts of the project like Diabetic retinopathy, Convolutional Neural Networks (CNN) and Transfer learning. Further section elaborates the hardware and software used in the project in detail. All this is comprised in the Chapter and we get thorough and brief details of the working system. Each section thoroughly elaborates its contents. All the concepts which are explained in detail here are the fundamentals used to understand the working principle behind this project. Hence, let us go through, understand and evaluate the Flowchart and proper description of each and every concept of the proposed system.

Figure 1 shows the Block diagram of the system. Each and every step involved in the design and development of the system is shown here. We start by collecting the dataset and after the necessary processing of the data and model training, we finally achieve the desired result i.e., Diabetes detection.

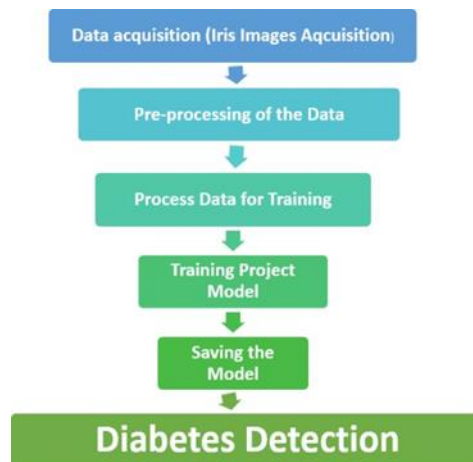

Figure 1: Block diagram of the system

We have proposed this system using the principles and understandings of Diabetic Retinopathy, Image Processing and Convolutional Neural Networks (CNN).

WORKING PRINCIPLE: The Proposed project uses the features of the Retina to detect the presence of Diabetes in an Individual. Diabetic Retinopathy screening is the working principle here, and accurate detection and good progress can be made using image classification, pattern recognition, and machine learning methods.

Following are the Prime concepts used in the implemented project:

DIABETIC RETINOPATHY: This is an after-effect of diabetes that damages the eyes. Diabetic retinopathy is brought about by harm to the veins in the body tissues at the backside of the eye

(retina). Improperly controlled blood glucose is extremely dangerous. At first, diabetic retinopathy may cause no side effects or just vague vision problems. Ultimately it can lead to visual impairment or blindness. This condition can arise in any individual who suffers from either type 1 or type 2 diabetes. The more you have diabetes and the less- controlled your blood sugar is, it is almost certain that you are going to develop this eye problem. By examining Diabetic Retinopathy, we can comprehend the how the glucose level influences the structure of the eye. Proliferative and non – Proliferative Diabetic Retinopathy are two phases.

Figure 2 shows a Normal and Diabetic Retina. It clearly indicates the differences in the structure of a person suffering from diabetes, compare to a healthy person. All the structural and organizational changes are clearly indicated.

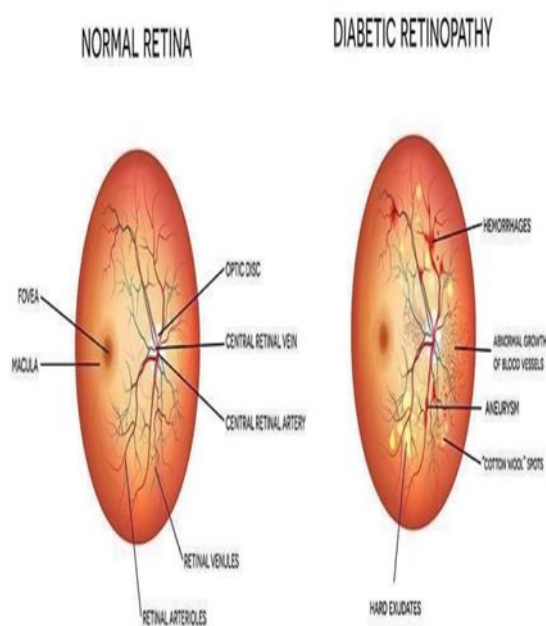

Figure 2: Normal and Diabetic Retina

CONVOLUTIONAL NEURAL NETWORKS (CNN):

Convolutional Neural Networks (CNN) is a concept of deep learning. A convolutional neural network (CNN, or ConvNet) is a specific class of deep neural networks, which is mostly applied to analyzing and classifying visual images or data. These networks are also called shift invariant or space invariant artificial neural networks (SIANN). They have applications in a number of domains like image and video recognition, recommender systems, image classification, etc. CNNs are the regularized versions or implementations of multilayer perceptrons. Multilayer perceptrons are fully connected networks, which means that, each neuron in one layer is connected to all neurons in the successor layer. CNNs use lesser pre-processing as compared to other image classification algorithms. This shows that the network itself learns the filters that in traditional algorithms were engineered manually by the operator or the programmer. This independence from previous information and human interference in feature design is a massive advantage. Hence, we are proposing a CNN approach for diagnosing Diabetes retinal images and accurately classifying their severity. We develop a network with CNN architecture and data augmentation which can identify the

intricate features involved in the classification task such as micro-aneurysms, exudates etc. through the retina and consequently provide a diagnosis automatically and without any user input. We train this network using the publicly available dataset i.e., Kaggle and demonstrate impressive results.

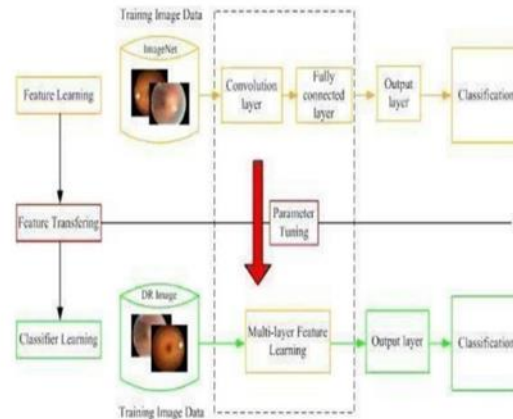

Figure 3: CNN for Diabetes Detection

Figure 3 shows the CNN (Convolutional Neural Network) for Diabetes detection. Here the sequential block diagram is shown. The model shows how the developed algorithm first collects the data, then learns the extractable features, does parameter tuning and in the end gives result in the form of Diabetes detection.

CNN architecture takes inspiration from the construction and working of the visual cortex of the human body and is created in order to mirror the connectivity and spiralling pattern of neurons inside of the human brain.

The neurons within a CNN Model are split into a three-dimensional structure. Each set of neurons do study and analyse a small area or feature of the complete image. We can say that, each group of neurons carries out the task of understanding and identifying one part of the image. CNNs take the help of these predictions from the layers to generate a resultant output that presents a vector of probability scores to represent the likelihood that a certain feature belongs to a particular class with surety.

Following are the basic layers of a CNN:

Convolutional layer – It creates a feature map to predict the class probabilities for each feature. It does so by adding a filter which scans the complete image, and it scans a few pixels at a particular time.

Pooling layer (down sampling) – The layer scales down the complete amount of data which the convolutional layer generates for each feature. It maintains the most important information (the task of the convolutional and pooling layers usually repeats many times).

Fully connected input layer – It flattens the outputs generated by previous layers and then converts them into a single vector so that, they can be used as an input for the next layer.

Fully connected layer – It applies weights over the input generated by using the feature analysis. The result is the prediction of an accurate label for the input.

Fully connected output layer – It generates the final probabilities to determine the final classification for the input data (usually pixel data).

The layer of Batch Normalization increases the level of learning and understanding for each layer. The output of the preceding layers is normalized using this technique. The activations perform scaling of the input layer in normalization. It is an effective way of regularization of avoiding overfitting of the model. It further makes learning more efficient. For the standardization of the inputs as well as the outputs, it is added to the sequential model. We have the freedom of using it anywhere between any given layers or elements of the Model. Usually, it is positioned after defining the sequential model and after the convolutional and pooling layers.

Dropouts are the regularization methods which perform the task of preventing overfitting in the model. They are added to the randomly switching elements which form some percentage of neurons of the total Convolutional Neural network.

After switching off the neurons, their respective incoming and outgoing networks are also switched off. This technique better the learning process of the model. It is advised that we should use Dropouts after the denser layers of the network and not the Convolutional layer. We should always switch off the neurons to only 50%. Switching off more than 50% can lead to improper model learning and inaccurate predictions.

Activation Functions: These are one of the most important elements of the CNN model. They basically find out and approximate any kind of continuous and complex relationships or connections between variables or elements of the complete network. Basically, they take the call on the decision that which information of the model should go in the forward direction and which ones should not at the termination of the network. It imparts a kind of non-linearity to the network. Few commonly used activation functions are - ReLU, Softmax, tanH and the Sigmoid functions. Each of these functions have a specific usage and features. For a binary classification CNN model, sigmoid and softmax functions are preferred whereas for a multi-class classification, most of the times softmax is used.

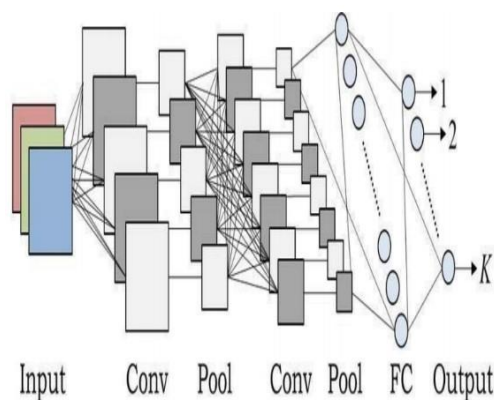

Figure 4: CNN Architecture

diabetes detection using convolutional neuralnetworks (cnn) based model

Figure 4 shows the CNN (convolutional Neural Networks) Architecture. It shows the proper sequence of all the working layers involved like Convolutional, Pooling and Fully Connected layer

Software and Hardware Requirements:

The complete CNN model is created using Python programming language on the platform of Google Collab. Other required libraries like TensorFlow, Keras, Numpy, etc. have been installed accordingly.

The only hardware required for this Diabetes detection system is the device for collecting the raw input data i.e., the Retina image (Left and Right Eye) of the patient. For this purpose, various tools used by Ophthalmologists or other like I- Scan-2 dual iris scanner can be used.

Implementation Methodology:

We have high resolution Retina Images of the person to be tested as input data. A left and Right eye image (Retina Image) is present for each subject. Our proposed automated system will detect the presence of Diabetes in the individual based on Diabetic Retinopathy.

The system will also predict the level of Diabetes in each subject on a scale of 0 (zero) to 4 (four) according to the following considerations:

0-non-Diabetic 1-Mild

2-Moderate 3- Severe

4- Proliferative Diabetes



Figure 5: Raw, unprocessed Input Data

Figure 5 shows Raw, unprocessed input data which is unprocessed and used for training the model has been taken from Kaggle.

PRE – PROCESSING OF THE DATA:

Pre-processing of the data basically involves the following three (3) tasks:

Cropping: It is basically the removal of unwanted outer areas from a photograph or an illustrated image. This activity can be performed on a physical photograph, artwork, or film footage depending on the application or it can also be achieved digitally by using image editing software.

Rotation: Image rotation is one of the frequently used image processing techniques with various applications in the domains of image matching, alignment, and other image-based algorithms. The

input to an image rotation process is basically an image, the rotation angle is θ , and a point about which rotation is done is also considered.

Image Augmentation OR Mirroring: Image data augmentation is a method which can be used to artificially increase the size of the training dataset by creating other modified versions of images in the dataset. Image data augmentation is used to improve the performance and ability of the model to generalize and henceforth, classify.

This step is carried out in order to remove the unwanted sections of the image and modify all the images to a standard form of input data. Feature Extraction is also done in this part.

PROCESS DATA FOR TRAINING:

Processing data for Training basically involves the following two (2) tasks:

Image Normalization: Normalization is a process which changes the range of pixel intensity values. An application example can be photographs with poor contrast due to glare. Normalization is also known as contrast stretching or histogram stretching

Lower or Amplify the Data Set images to the same standard size of 64x64 pixels.

This step is an extremely crucial one. Here we decrease the size of the data in order to lessen the complexity of the whole mechanism. Also, the data which is too less in size is amplified for training by using methods like Padding.

TRAINING PROJECT MODEL:

This step is the most important one. Here, the selected Model will take the pre-processed data i.e., the iris images as input. Further, it will execute itself and finally give the output which is the prediction of Diabetes presence in the subject. Predominantly, accuracy of the training model depicts the accuracy and the reliability of the project.

SAVING THE MODEL:

This is the final step, wherein after the successful execution and achievement of desired accuracy, we finally save the model. We wish to create a prototype of this model. The final product which we aim to achieve is a website or an application.

This project when implemented will prove to be very beneficial as it automates the detection of one of the most life-threatening disease – Diabetes. It will also save the patients from discomfort and pain as this method is non – invasive. This way earlier detection and treatment of the disease is possible. Hence, due to its many advantages this method has wide applications in the medical domain for efficient and comfortable Diabetes detection.

Advantages: It is a non – invasive technique, hence it is very comfortable for the patient. It provides early detection i.e., much before the symptoms appear. It is also economical. It is reliable and has great accuracy.

4 RESULTS

After implementing the technique of CNN and the principle of Diabetic retinopathy, we were finally able to devise a system which successfully detects the presence or absence of Diabetes and also gives the level of Diabetes present. We have achieved an accuracy of 93% on the Training dataset and an accuracy of 75% on the validation dataset.

The end product is a Graphical user Interface (GUI) which successfully detects the level of Diabetes present in an individual.

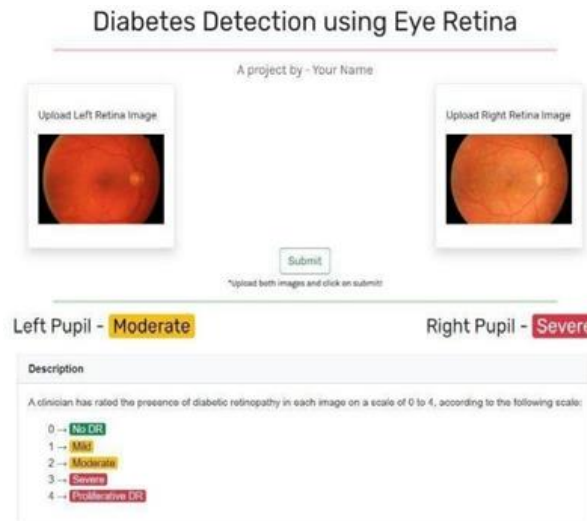

Figure 6: GUI of the implemented system

Figure 6 shows the Graphical User Interface of the system. The GUI is kept simple to make the process less complicated and the product, user friendly.

Cost and Benefit Analysis:

As we have established, this project is extremely cost effective and economic. The major expenses would go into the collection of datasets, i.e., retinal images. For this purpose, various tools used by Ophthalmologists or others like I-Scan-2 dual iris scanner can be used. Later part of predictive models falls on the cost-effective side.

5 CONCLUSION AND FUTURE SCOPE

Hence, we have proposed this system for Diabetes detection using Iridology and a thorough understanding of Diabetic Retinopathy. We have obtained the retina images (left and right) of the subjects to be tested and further processed them to make the raw input data in a proper standard form. Further, the processed images are fed into the proposed Convolutional Neural Networks (CNN) model. Even a transfer learning model can be used. These models provide a very efficient method of diabetes detection. These models are trained using a large dataset which we have obtained through publicly available platforms. Using this simple and efficient technique we have successfully carried out the process of Diabetes detection. At this stage, we successfully implemented the model and obtained results. The system is quite efficient and carries out multiparameter classification for Diabetes detection. The selected model uses the learnings and knowledge of Iridology and Diabetic

Retinopathy. The proposed system has wide applications in the medical domain for Diabetes testing. This test is extremely simple, efficient, and non-invasive compared to the conventional method. These features make it extremely comfortable for the patient. This system once implemented will also be very economic and cost-effective. Hence, it can also be implemented as a part of the regular precautionary check-ups in the future. This will help the subjects who are detected as Diabetes positive can start the treatment early. Early starting of treatment will help in better disease control and may even help some people to go into remission.

Thus, the proposed project has many applications as well as immense advantages. The proper implementation of this can provide efficient and extremely quick Diabetes detection. When used on a large scale, with improvements in the prototype, it will drastically benefit everyone. We are also continuously working on identifying new features that might provide more valuable information on patient conditions like the level of Glucose, Insulin, etc. Also, with continuous work and improvement the accuracy and the efficiency of the project can be further increased. Hence the project holds a lot of future scopes and constant system evaluation and improvement in the prototype will lead to the creation of a flawless and efficient Diabetes detection system.

Acknowledgment

The authors are immensely grateful and thankful to Ramrao Adik Institute of Technology for giving us the opportunity and support required to carry out this project work properly. A sincere thanks and appreciation to Prof. Bhavesh Digey, who guided us throughout the project and helped us to overcome all the difficulties which we faced in the course of the project preparation.

REFERENCES

1. Diagnosis of Diabetes using Computer Methods: Soft Computing methods for Diabetes detection using Iris, World Academy of Science, Engineering and Technology Conference, pages 1-6, 2019
2. Diabetes Prediction System based on Iridology using Machine Learning, IEEE Conference, Semarang, Indonesia, pages 1-9, 2011
3. Iridology Simplified by Bernard Jensen, Book Pub Co; 5th Edition, 2011.
4. Neural Networks and Deep Learning by Pat Nakamoto, CreateSpace Independent Publishing Platform, 2018.
5. Christopher picture publications, [https:// www.christopherpublications.com/Iridology.html](https://www.christopherpublications.com/Iridology.html), Accessed 13 Mar. 2011
6. Carolina Research, [https:// www. carolinaeyecare.com/retina-charleston/diabeticretinopathy/](https://www.carolinaeyecare.com/retina-charleston/diabeticretinopathy/), Accessed 12 April, 2003
7. Science direct research, [https:// www. sciencedirect.com/science/article/abs/pii/S0045790618302556](https://www.sciencedirect.com/science/article/abs/pii/S0045790618302556), Accessed 8 January, 2011
8. Research gate association, [https:// www. researchgate.net/figure/An-example-of-CNN-architecture_fig1_320748406](https://www.researchgate.net/figure/An-example-of-CNN-architecture_fig1_320748406), Accessed 14 November, 2017
9. IBM Tech, [https:// developer. ibm.com/ technologies/artificialintelligence/articles/transfer- learning-for-deep-learning/](https://developer.ibm.com/technologies/artificialintelligence/articles/transfer-learning-for-deep-learning/), Accessed March 2019.
10. Image augmentation methods by slide Share <https://www.presentation-from-xperi>, Accessed 18 May 2009.