

Modernization of Agricultural System Using Raspberry Pi

Mr. Baljinder Singh

Guru Kashi University, Talwandi Sabo

Abstract

This project is mainly designed to solve the problems of farmers. An intelligent drip irrigation system optimizes use of water for agricultural crops using sensors and Raspberry pi. The sensor networks consists of many sensor nodes, hub and control unit. The sensor collects real-time data such as salinity, conductivity, crop height detection. This data is sent to the hub, where the data is processed by Raspberry pi. It checks for the predefined value. Based on the distribution of the water, conductivity of soil will be detected by conductivity sensor and hence the motor is turned OFF, and similarly we are monitoring the height of crop with the help of LDR sensor, similarly other applications are implemented. System acts as communication link which display the working of whole system. Raspberry will calculate water demand for crops quickly and accurately, which can provide a scientific basis for water-saving irrigation.

1. INTRODUCTION

Agriculture is one of the powerful word that the world is witnessing at the moment. With the help of agriculture, we the people of the world are able to survive. But for the agriculture process to take place lot of money is invested. Sometimes due to the climatic conditions the crops are wasted which results in heavy losses. In order to reduce the loss and increase the output of agriculture new technologies are coming into place. Water is a basic component of all life. Water is also a very precious natural resource that must not be wasted. If too much water is applied the problems rise up depending upon the soil texture. If too little water is applied different problems arise such as improper growth of the crops. The idea of irrigation is not new, irrigation stems as far back as the Egyptians and probably further in unrecorded history. Even the idea of automated irrigation is not new, mankind has figured out how to irrigate large areas of foliage through the use of automated and drip irrigation systems. Efficient, automated irrigation systems, which can irrigate plants to a desired level and supply those plants with just the amount of water required for normal an uptake plant growth, are currently not available. These systems, if developed, could reduce waste of irrigated water. The main objective of the project is to automate the irrigation system by monitoring the various parameters like conductivity, salinity and also crop growth detection using opto coupler take necessary actions by processing these input data through a raspberry controller and displayed through the monitor. The technique also includes the utilization of renewable energy resource like solar energy so as to power up the controller and other low voltage devices.

**The Hardware Description:
PRINCIPLE OF OPERATION**

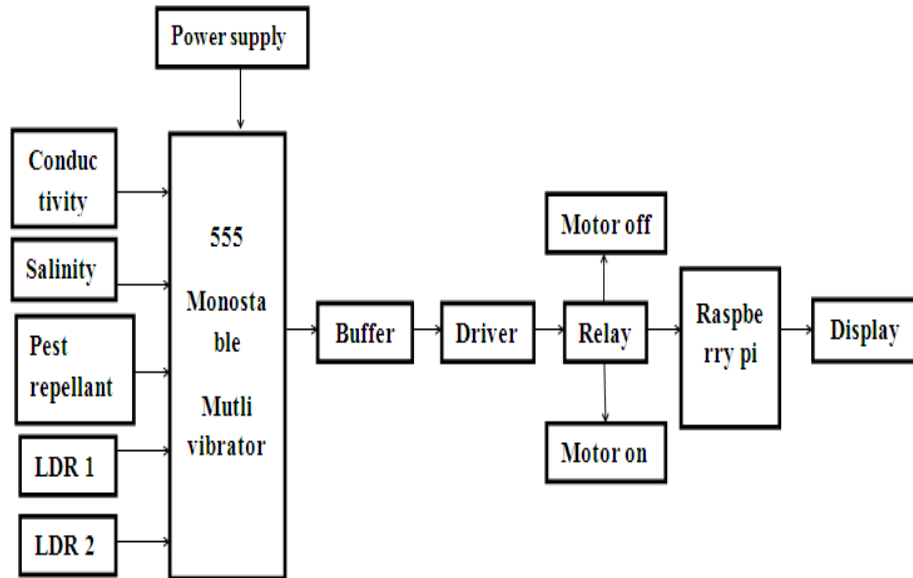

Fig3: Block Diagram of the project

This project is mainly designed to solve the problems of farmers. This consists of Raspberry Pi, Display, Conductivity, Salinity sensors, LDR (for height) Dynamo relay and motor. The sensor will sense the soil content and fed to the controller. In controller, it checks for the predefined value then it generate the output that is fed to buffer IC 4050, buffer stores and given to the driver IC 2003. In driver, current will amplifies and voltage will inverts with the help of Darlington pair circuit of the driver IC to drive the relay. Then signal is given to the output load to return ON the motor or to turn OFF the motor. Based on the distribution of the water, the field will be detected by conductivity sensor and hence it will be turned OFF, And similarly we are monitoring the height of crop with the help of LDR sensor, similarly other applications are implemented

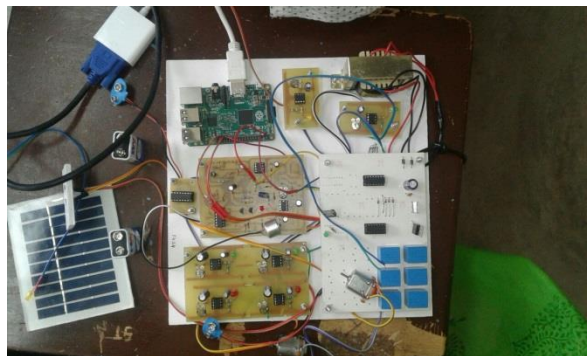

Fig4:Complete Project kit

ADVANTAGES

- Water conservation problem will be solved.
- Less evaporation losses of water as compared to surface irrigation.

Modernization of Agricultural System Using Raspberry Pi

- Maximum crop yield.
- No man power required.
- Reduce soil erosion and nutrient leaching.

DISADVANTAGES

- High skill is required for design, install and operation.
- High cost compared to furrow.
- High skilled is required for design install and operation.

APPLICATIONS

- In the field of agriculture
- Implemented in the field of nursery.

CONCLUSION:

The objectives of this project is to avoid wastage of water and increase irrigation efficiency by using Raspberry Pi based irrigation system with the help of conductivity salinity sensor, LDR, Plant growth height sensor.

Smart irrigation control technology is easily deployable and can be controlled manually or automatically without physical presence at the field.

FUTURE DEVELOPMENTS OF THE PROJECT:

The working of the project is basically dependent on the output of the sensors. Whenever there is need of excess of water in the desire field then it will not be possible by using sensor technology. For this we will have to adopt the DTMF technology. By using this we will be able to irrigate the desired field and in desired amount.

Water resource can be utilized efficiently and effectively based on various other parameters so that agricultural sector become more productive. Automatic drip irrigation at different seasons is another future scope. Water is allowed to the field of crops depending upon the particular season.

REFERENCES:

- [1] KoushikAnand , (TIAR 2015) : Automatic drip irrigation system using fuzzy logic and mobile technology .
- [2] Howell, T.A. (2001): Enhancing water use efficiency in irrigated agriculture. Agron.J, 93, pp.281-289.https://www.researchgate.net/publication/43255582_Enhancing_Water_Use_Efficiency_in_Irrigated_Agriculture.
- [3] VeenaDivyak ,AyushAkhouri, A real time implementation of a GSM based Irrigation Control System using drip irrigation methodology(volume 4, issue 5,may2013).
- [4] Wright, J.L., 1982. New evapotranspiration crop coefficients. Journal of irrigation and drainage division, ASCE,J108:57-74.
- [5] Or, D.,2005. Soil water sensors placement and interpretation for drip irrigation management in heterogeneous soils. In: proceeding of 5th international micro irrigation congress